

MRI-compatible bone-conduction sound stimulation

Romain Poos, Bruno Nazarian, Régis Trapeau,
Etienne Thoret, Xavier Degiovanni, Julien Sein, Richard Kronland-Martinet, Adrien VidalJean-Luc Anton



Purpose : Auditory diffusion in an MR scanner

- Human Primate
 - Auditory stimulation – Functional tasks
 - Communication with the participant
 - Relax the participant (music, film)
 - Active Noise Cancelling (ANC)

Purpose : Auditory diffusion in an MR scanner

- Non-Human Primate : Auditory stimulation
 - Separate HP / NHP devices
 - Difficulty to use ear plugs
 - Dedicated system
 - Big challenge for Marseille (f)MRI Primate Community

Purpose : Constraints

- Protect the participant ear
- Play a sound that may contain frequencies close to EPI noise
- Ensure a minimum level of comfort

About Sound : Production

- Principle : Mechanical wave propagating in a medium
- The wave is generated by a (bio-) mechanical vibrating component
- The characteristics of the medium (density, confinement, shape, temperature, pressure, etc.) affect sound

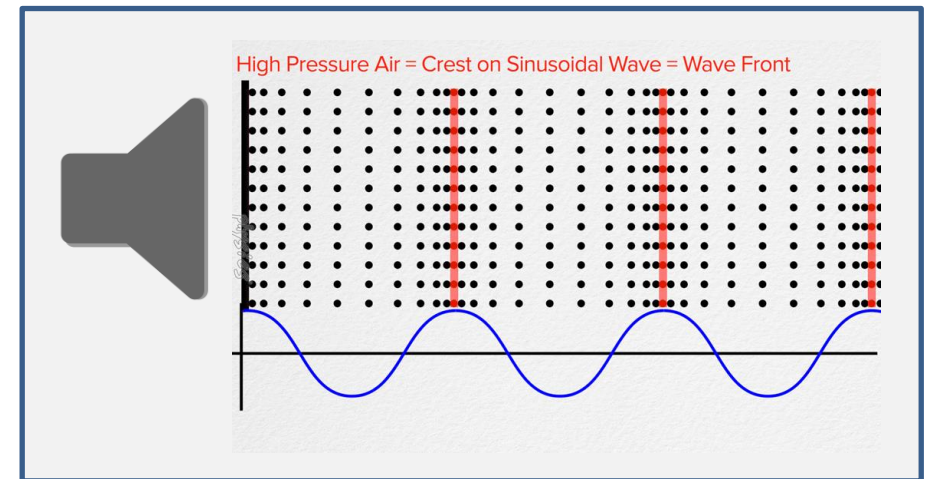

About Sound : Production

- Propagation of energy \neq Propagation of medium

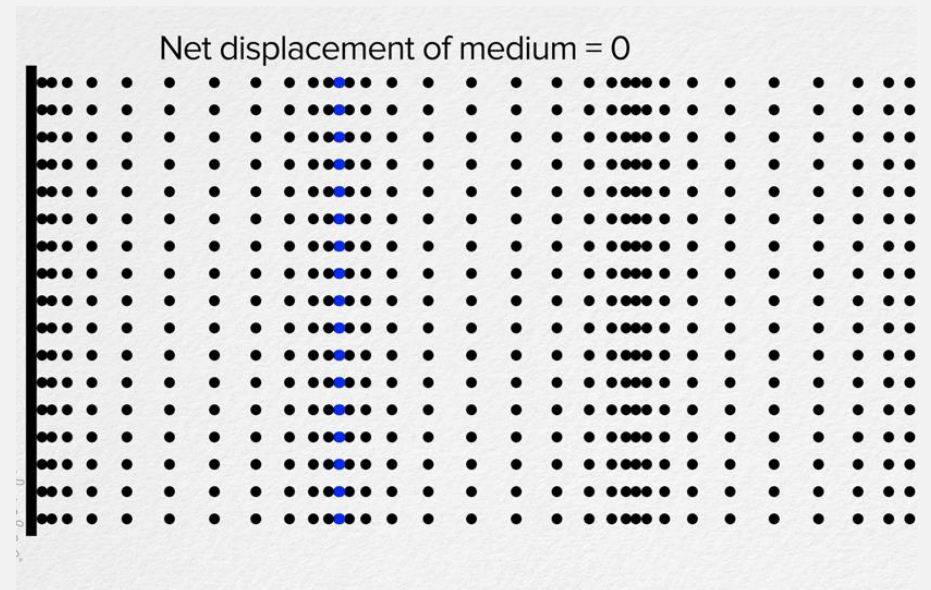
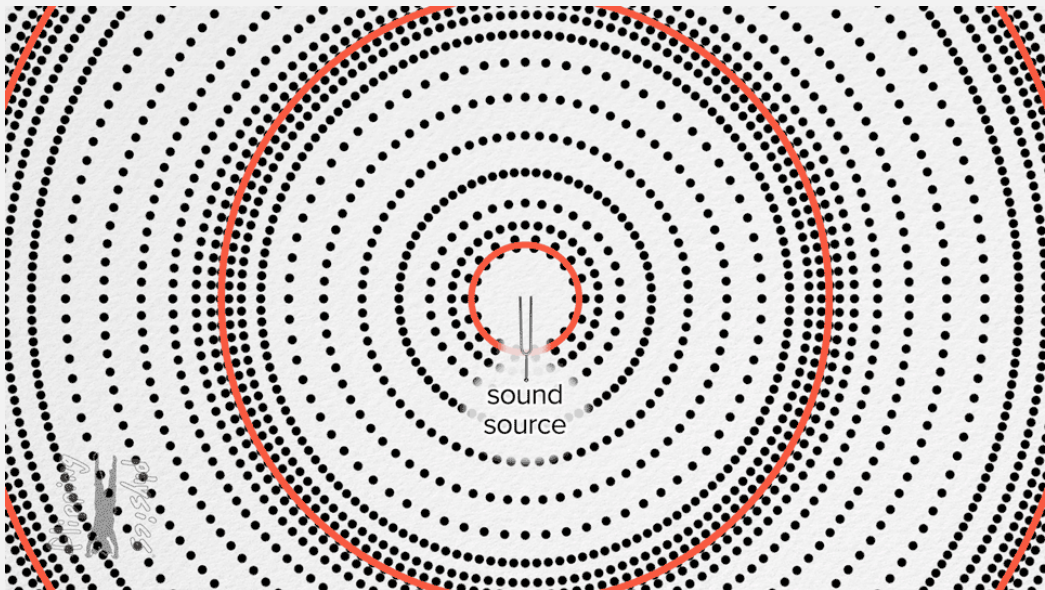

About Sound : Production

- Propagation media
 - Air / Gas
 - Water / Liquid
 - Metal / Solid

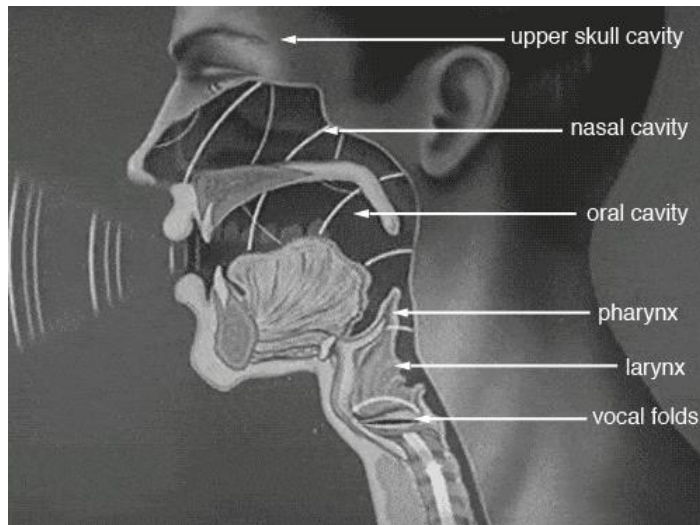

- Propagation way
 - Modulation
 - Acoustic impedance
 - Articulation process

Medium	v_w (m/s)
Gases at 0°C	
Air	331
Carbon dioxide	259
Oxygen	316
Helium	965
Hydrogen	1290
Liquids at 20°C	
Ethanol	1160
Mercury	1450
Water, fresh	1480
Sea water	1540
Human tissue	1540
Solids (longitudinal or bulk)	
Vulcanized rubber	54
Polyethylene	920
Marble	3810
Glass, Pyrex	5640
Lead	1960
Aluminum	5120
Steel	5960

About son : Perception

- Perception: the wave (pressure fluctuations) induces a (bio-)mechanical receptor to vibrate
- A (biomechanical) conditioning system amplifies and transfers the vibration
- Vibration is converted into a signal (information)

About sound : Perception

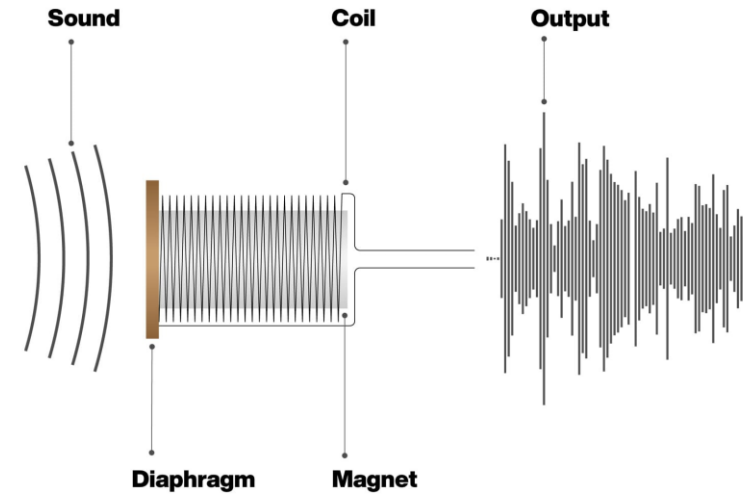
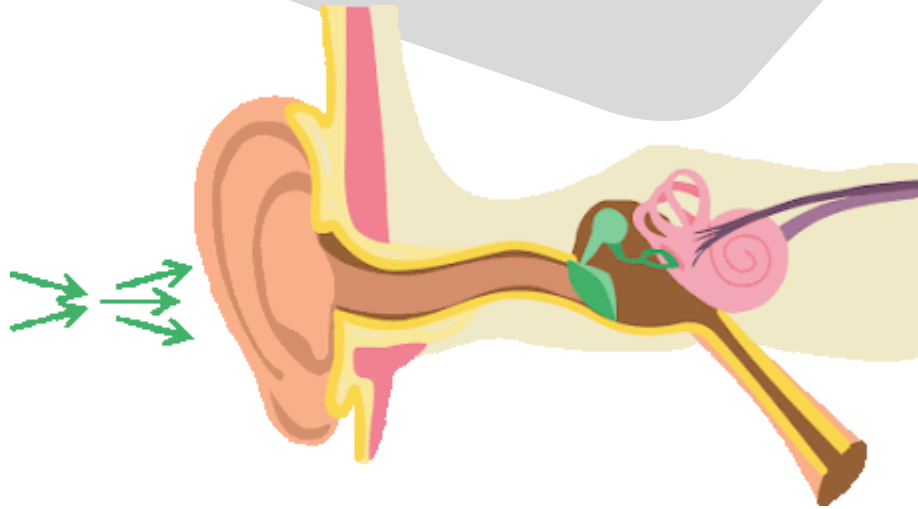

History and State of the Art

- Bruker 3T – 2 channels headcoil

History and State of the Art

- Bruker 3T – 2 channels headcoil
– Piezoelectric headset



Perception de la parole et IRM : réalisation, évaluation et validation d'un système permettant une stimulation sonore de qualité en cours de séquence IRM

*Alain Ghio**, *Bernard Teston**, *Cheryl Freck-Mestre**, *Corine Astésano***, *Daniele Schön***,
*Bruno Nazarian****, *Muriel Roth****, *Jean-Luc Anton****

* Laboratoire "Parole et Langage", Université de Provence, 29 Av. R. Schuman, 13621 Aix-en-Provence, France
Tel : +33 (0)4 42 95 36 30, Fax : +33 (0)4 42 59 50 96, Mél : alain.ghio@lpl.univ-aix.fr, www.lpl.univ-aix.fr

** Institut de Neurosciences Physiologiques et Cognitives, CNRS, Marseille, France

*** Centre IRM recherche, Hôpital de la Timone, Marseille, France

XXVèmes Journées d'Étude sur la Parole, Fez, 2004

History and State of the Art

- Bruker 3T – 2 channels headcoil
– Piezoelectric headset



Principle: Based on the ionic structure of the medium (crystal, ceramic)

Electrically balanced at « default state »

Unbalanced when distorted

Creation of electrical potential

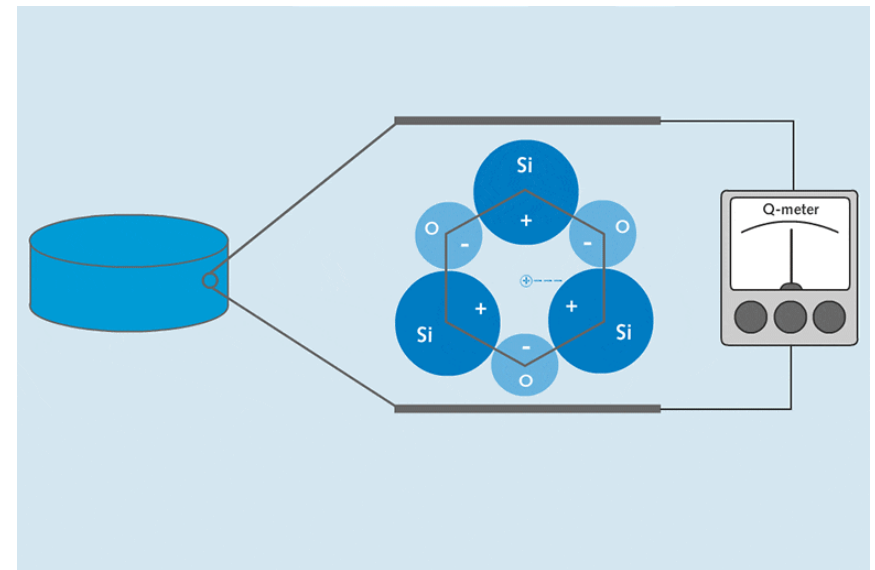

The piezoelectric component

Physical principle and applications in auditory stimulation via bone conduction

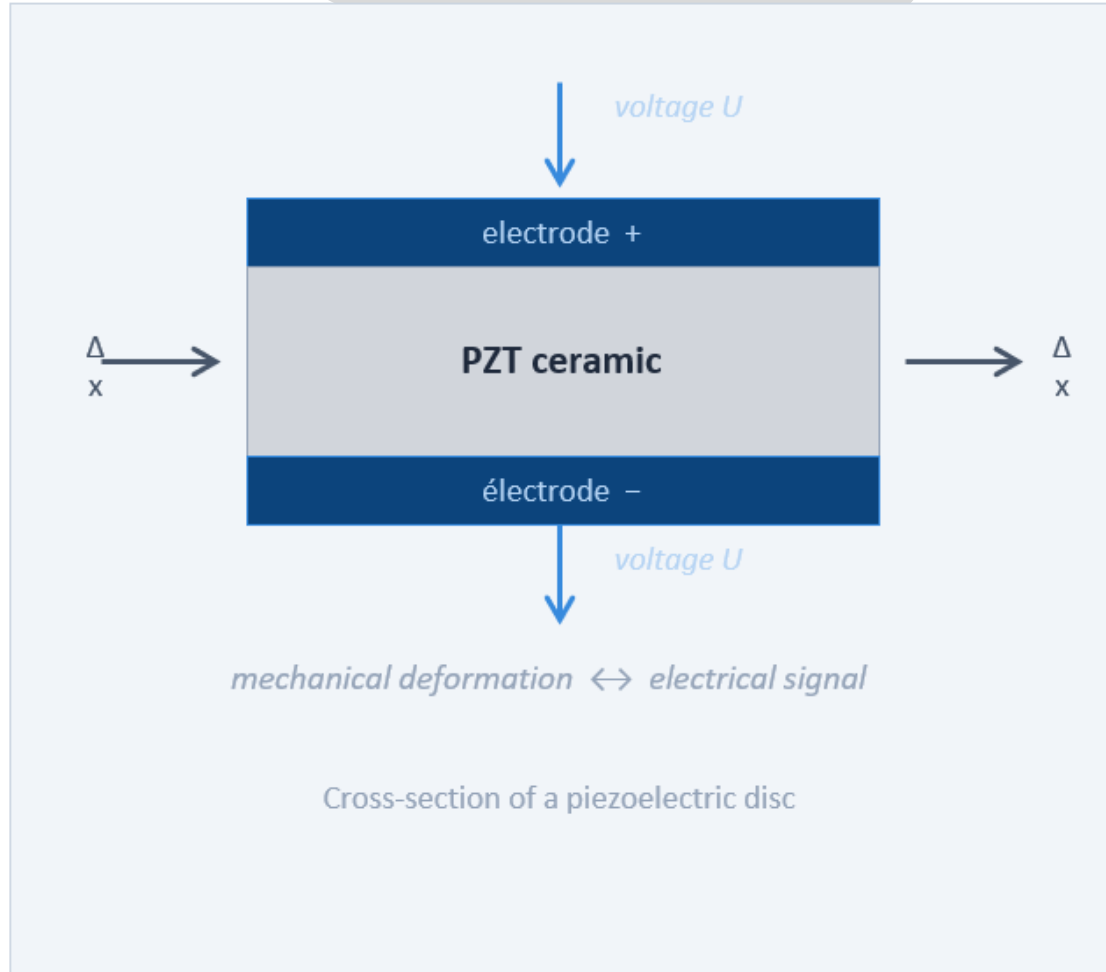

PRINCIPLE

Piezoelectric effect

Applying a voltage to a PZT ceramic causes a mechanical deformation. Conversely, compressing the material generates a voltage.

KEY PROPERTIES

Reversible

Works as both emitter (actuator) and receiver (sensor) depending on signal direction.

No moving parts

Robust, silent, low power consumption, very long lifespan.

Scalable & miniaturizable

Integrates into compact systems — from micro-scale to macro-scale.

APPLICATIONS

Buzzer

Microphone

Vibration sensor

Actuator

Bone stimulation

History and State of the Art

- Bruker 3T – 2 channels headcoil
 - Piezoelectric headset
 - Pneumatic Headset

Principle: Transporting the sound generated by a 'large' loudspeaker to the subject's ears via a pipe system

Beware !!!!

- Pressure level near the tympanum
- Acoustic impedance



History and State of the Art

- Bruker 3T – 2 channels headcoil
 - Piezoelectric headset
 - Pneumatic Headset
 - MR Confon electrodynamic sytem

Principle: Classical headphones ... without magnet

The headset coil is moving using the MR magnet field

Only usable in an MR scanner

Big size anyway



History and State of the Art

- Bruker 3T – 2 channels headcoil
 - Piezoelectric headset
 - Pneumatic Headset
 - MR Confon electrodynamic system
- Siemens PRISMA 3T – 20 / 64 channels headcoil
 - Sensimetrics S14 hearplugs



History and State of the Art

- Bruker 3T – 2 channels headcoil
 - Piezoelectric headset
 - Pneumatic Headset
 - MR Confon electrodynamic sytem
- Siemens PRISMA 3T – 20 / 64 channels headcoil
 - Sensimetrix S14 hearplugs
 - OptoActive by OptoAcoustics



Why a new system ?

- « Old headsets » : Mostly a size problem
- Sensimetrics S14 :
 - Sometimes painful
 - Sometimes not properly fitted
- OptoActive :
 - ANC only working during EPI runs
 - Used with passive earplugs : less sound heard
- Acoustic stimulation on NHP

Way to bone conduction

- Romain POOS
- Engineer apprentice, Computer & Instrumentation

Why Bone Conduction?

1

Protect ears from MRI noise

MRI sequences generate intense noise (up to 130 dB). Earplugs and noise-canceling headphones are mandatory, which blocks the auditory stimulus.

2

Bypass the outer ear

Bone conduction transmits vibrations directly via the skull to the eardrum/vestibule, bypassing the ear canal. Subjects can wear earplugs while still receiving the stimulus.

3

Pair with OptoActive

The BCO will complement the OptoActive system (active MRI noise reduction): together, they provide maximum protection from sequence noise while delivering a clean auditory stimulus.

Bone conduction

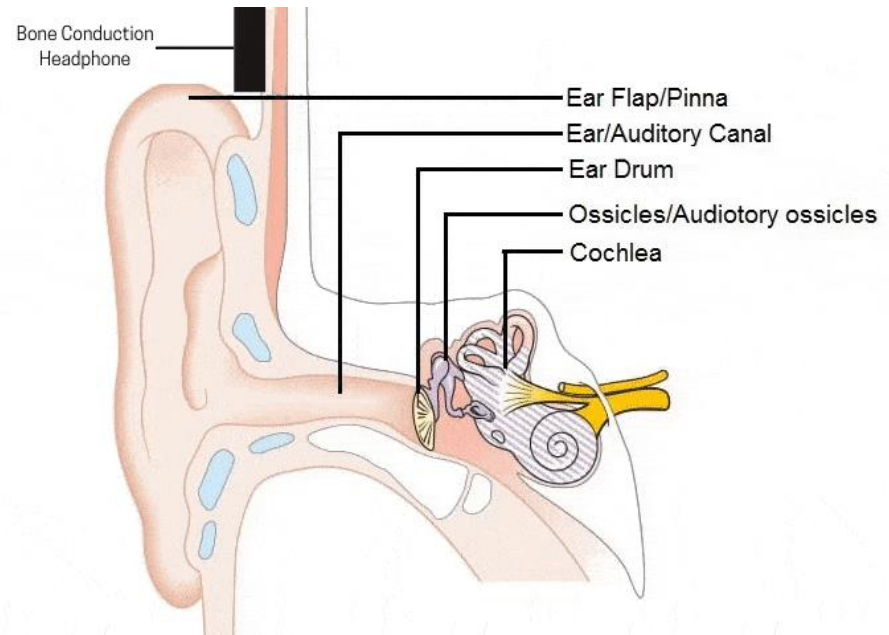
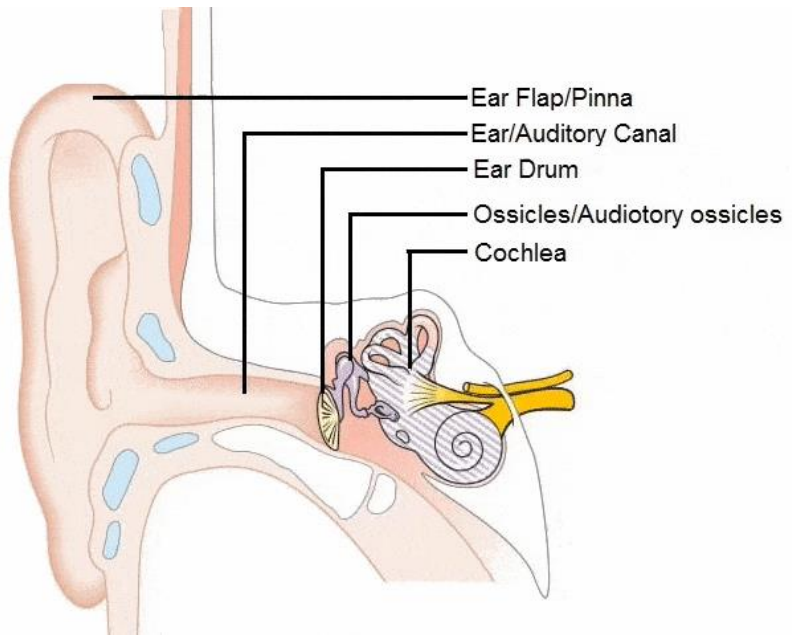

Technology Watch

Key Reference — Nota et al. (2007)

"A bone-conduction system for auditory stimulation in MRI"

Acoust. Sci. & Tech. 28, 1 (2007)

Described component: PZT02 (Eishin Electric)

→ unavailable for purchase

Direction: commercially available piezoelectric buzzers

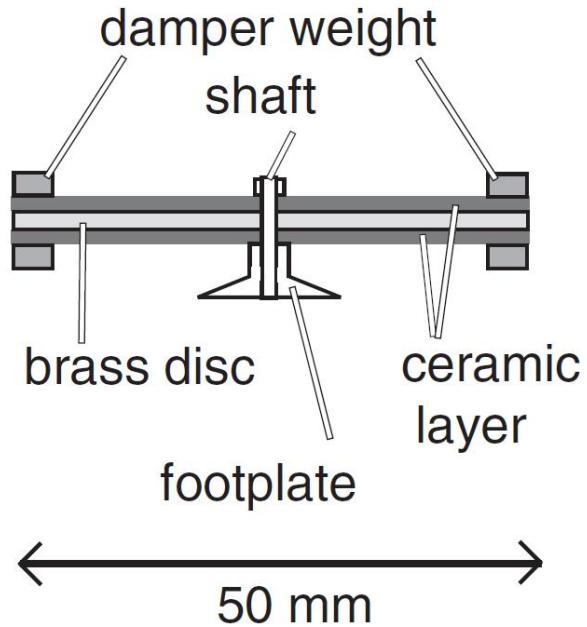

(a)



(b)

Tests & Component Selection

Proto 1
Feb. 2024



Amplifier

Sonitron PAA-BTL

Piezo Buzzer

SCS-32

Concept validated

Lacks power

Proto 2
Mar. 2024



Amplifier

MAX-9788

Piezo Buzzer

KPEG110 / PKD-7246

PKD-7246 ferromagnetic

X MRI-incompatible

Proto 3
May 2024



Amplifier

Yamaha P2075

Piezo Buzzer

KPEG827

MRI-compatible ✓

Markedly superior result

Ergonomic Frame Development

Collaboration with Xavier DeGiovanni (S-PrIME) — ABS 3D printing

Frame v1 — June 2024

- Frame for commercial piezo buzzers
- Forehead positioning
- Ergonomic MRI test (Bruno Nazarian, Julien Sein)

Baseline established

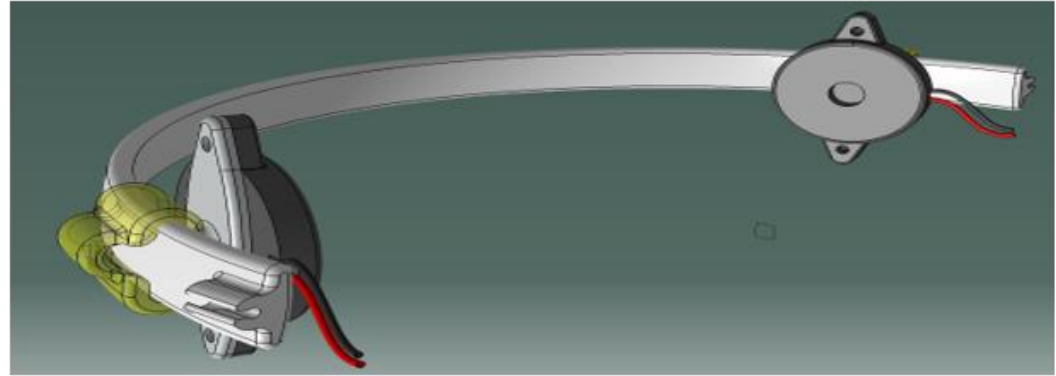

Towards Psychoacoustic Validation

On Hold

Jul.–Oct. 2024



Summer break then reactivation
— search for psychoacoustics
experts

Contact Etienne Thoret

Oct.–Nov. 2024



INT researcher, former PRISM
post-doc — ideal expert for
validation

MRI Tests

17 Dec. 2024



Acoustic & ergonomic tests. Used
with OptoActive system. Very
encouraging results.

Etienne Thoret contacts Richard Kronland-Martinet (PRISM) — the project takes on a new dimension

The Bimorph Piezoelectric Transducer

Monolayer (standard buzzer)

- Single piezoelectric layer
 - Designed to radiate sound into air
 - Low mechanical displacement
 - Not suited for solid-borne transmission
-

The Bimorph Piezoelectric Transducer

Monolayer (standard buzzer)

- Single piezoelectric layer
- Designed to radiate sound into air
- Low mechanical displacement
- Not suited for solid-borne transmission

Bimorph (Pi Ceramic capsule)

- Two opposing piezo layers
- Amplified mechanical deflection (bimorph effect)
- Direct vibration transmission to bone
- Designed for solid-borne vibration



The Bimorph Piezoelectric Transducer

Monolayer (standard buzzer)

- Single piezoelectric layer
- Designed to radiate sound into air
- Low mechanical displacement
- Not suited for solid-borne transmission

Bimorph (Pi Ceramic capsule)

- Two opposing piezo layers
- Amplified mechanical deflection
- Direct vibration transmission to the load
- Designed for solid-borne vibration

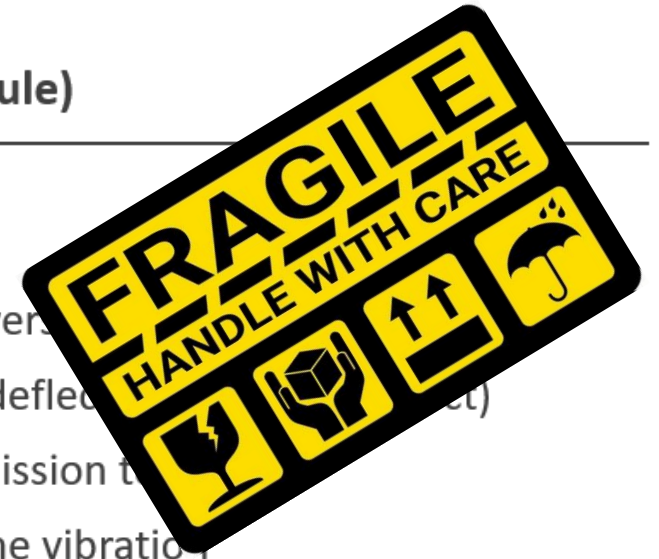

Conclusive results with Pi Ceramic capsules: MRI compatibility validated, audio quality markedly superior to previous prototypes

The Bimorph Piezoelectric Transducer

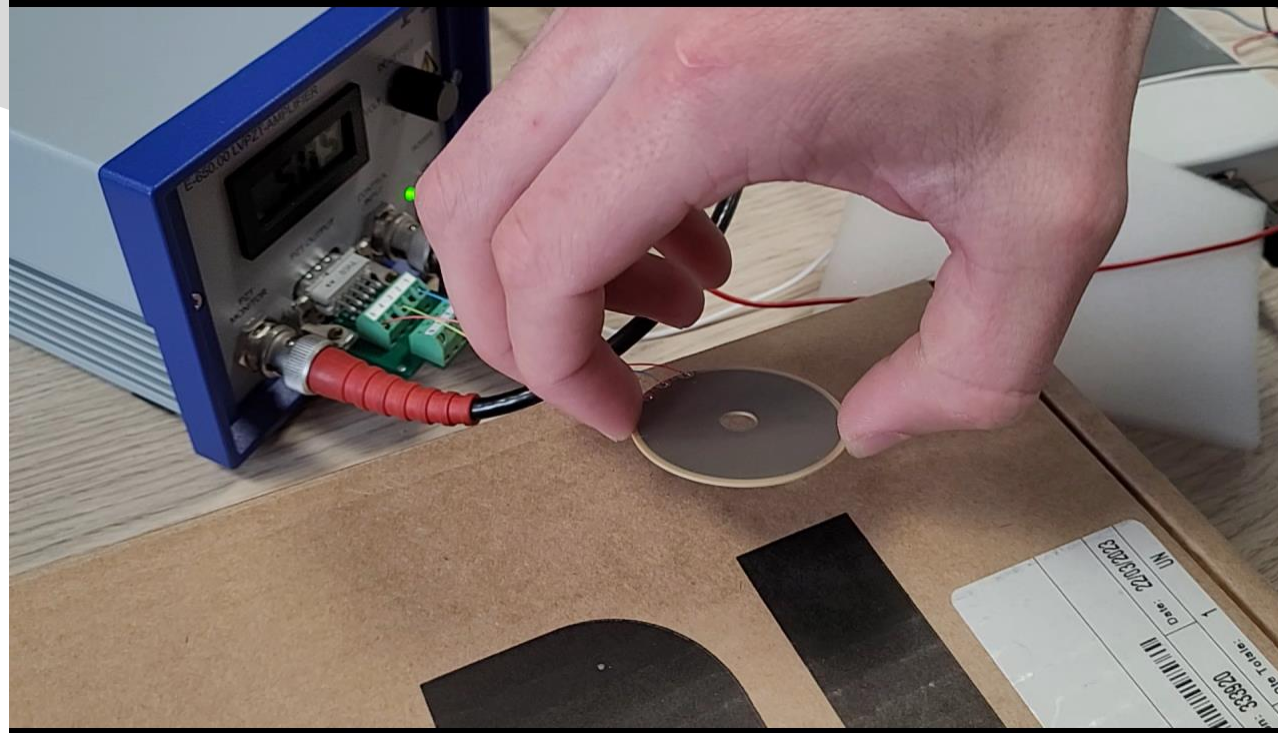

23/12/2025

Pi Ceramic Integration & Frame Development

First Pi Ceramic Tests

Oct.–Nov. 2025

Problem: original solder wires too thin → repeated breakage

Solution: custom, more robust wiring

Configuration: 2 capsules (one per side), mono signal duplicated via Yamaha P2075
→ symmetric bilateral output

Frame Development

Jan.–Mar. 2026 · Xavier DeGiovanni (S-PrIME) · ABS 3D

v1

Jan. 2026

First frame adapted for Pi Ceramic capsules

v2

Feb. 2026

Ergonomic adjustments

v3

Mar. 2026

Under-chin routing — easier insertion into 64-channel coil, more comfortable

Mechanical encapsulation

- New Design (Xavier Degiovanni)
- Specific work on the vibrator/skin interface

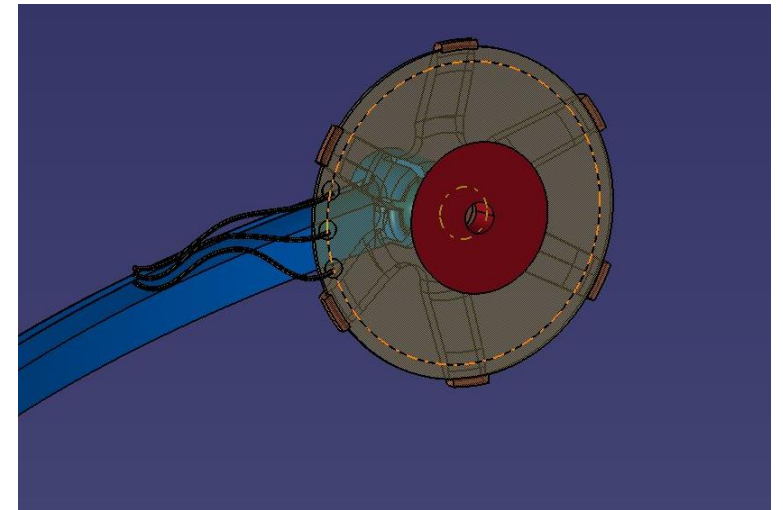
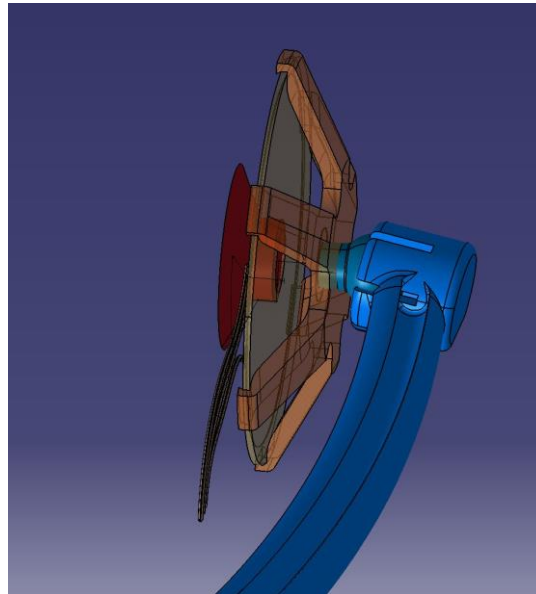
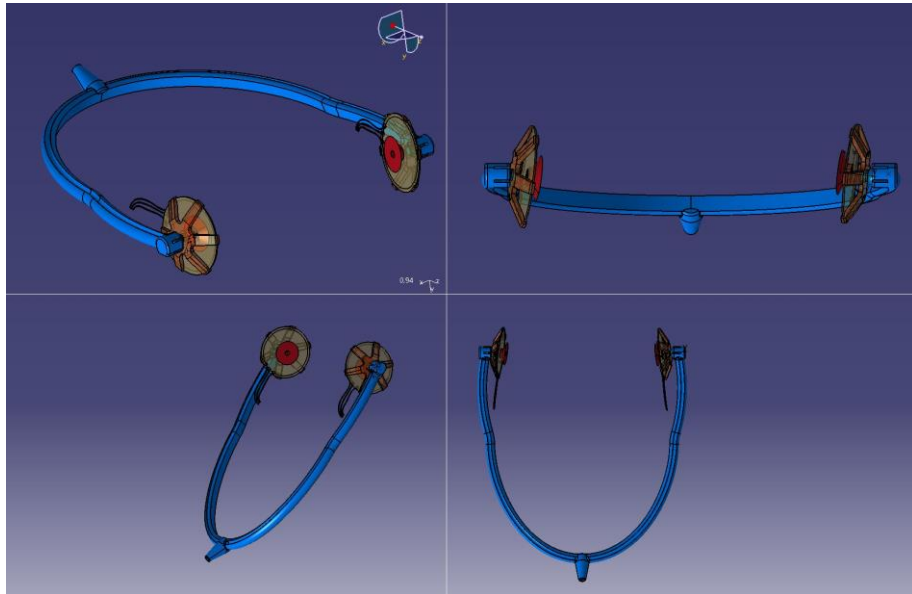

Ergonomy

- New Design (Xavier Degiovanni)

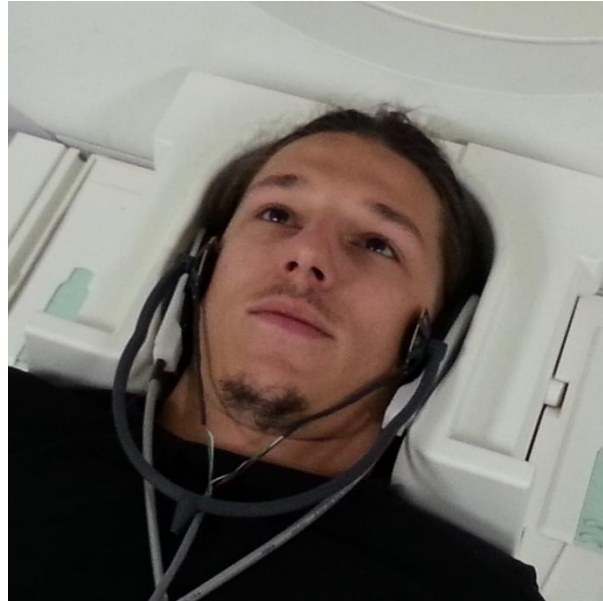
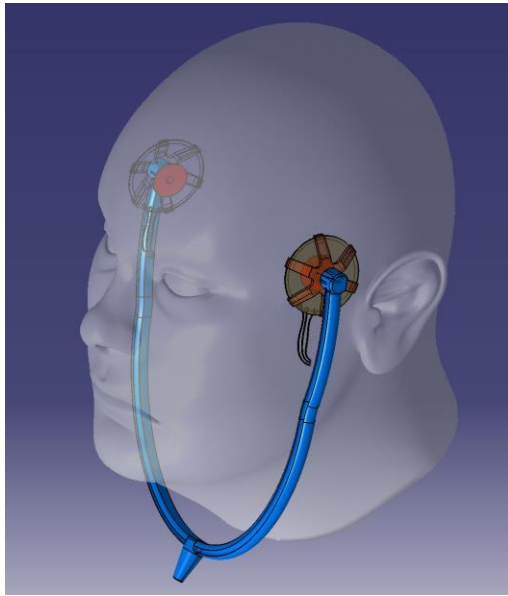

Acoustic validation

Principle

- Generation of a frequency variation signal (chirp)
- Vibration power spectrum analysis
 - Accelerometer
 - Dedicated acquisition & processing software

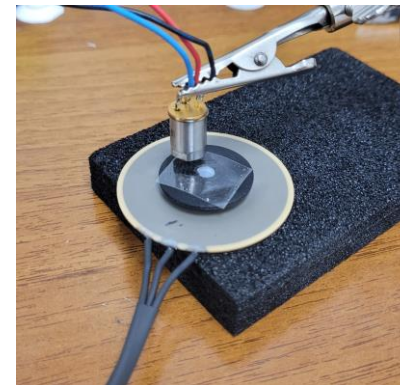
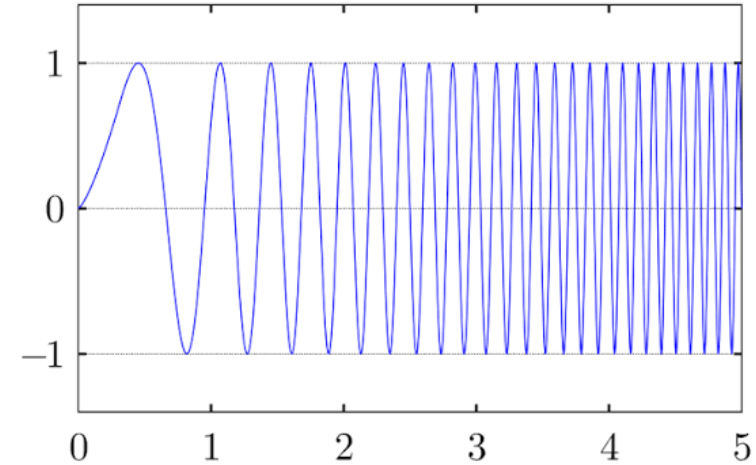

Acoustic validation

Results

- Time frequency analysis
- Spectral response

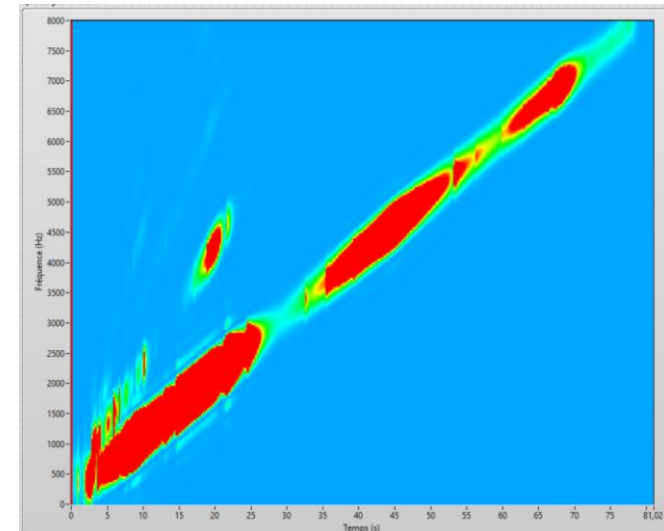
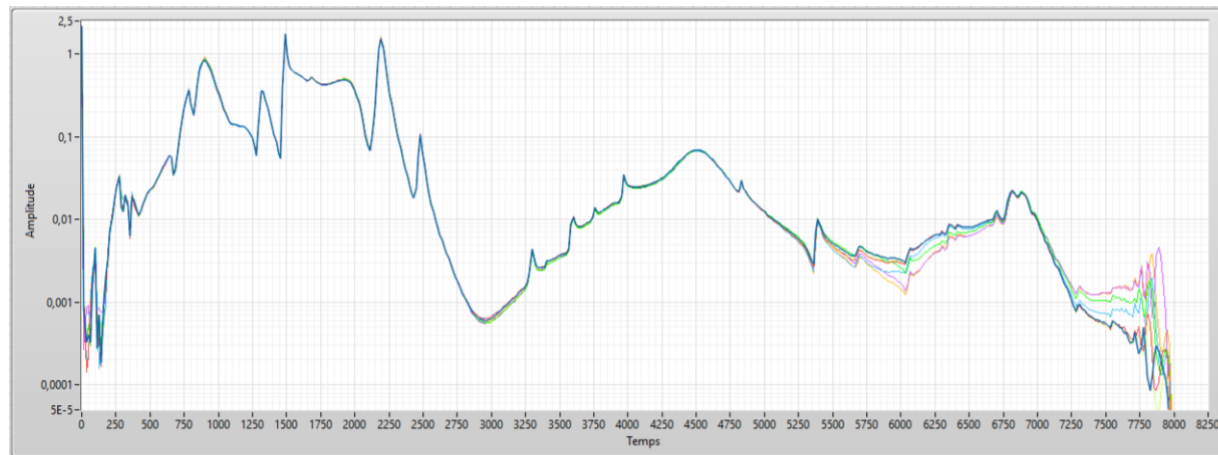

MRI Tests — Full System

02 April 2026 — Romain POOS (1st subject)

Full system validation
under real scanner conditions

Feedback: CCO + earplugs + OptoActive provides better protection from MRI sequence noise than Sensimetrics

vs

05 May 2026 — Etienne THORET (2nd subject)

Acoustic evaluation by an expert

Comparative: enables direct comparison with older piezo buzzers

Feedback: opposite to Romain's: expert input to guide further development

Divergent feedback → quantitative analysis (Régis TRAPEAU)

FMRI pilot – Voice Localizer

Subject 1

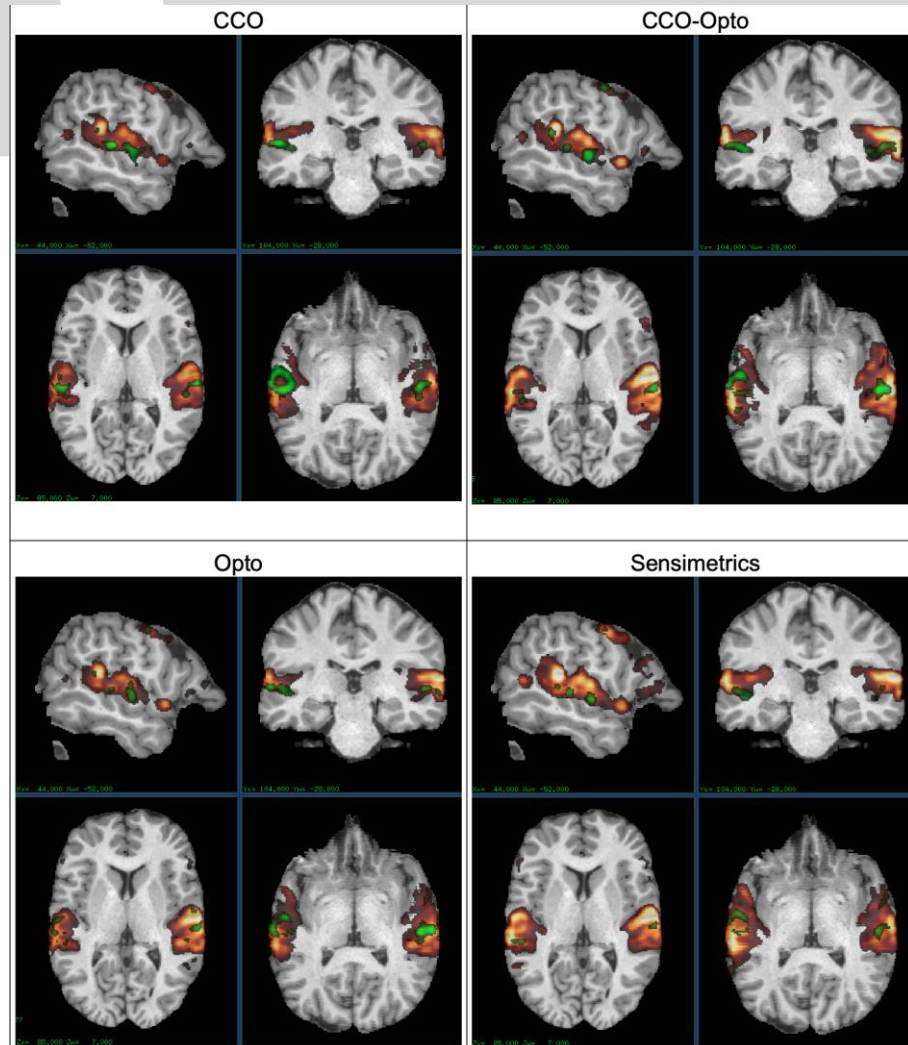

Subject 2

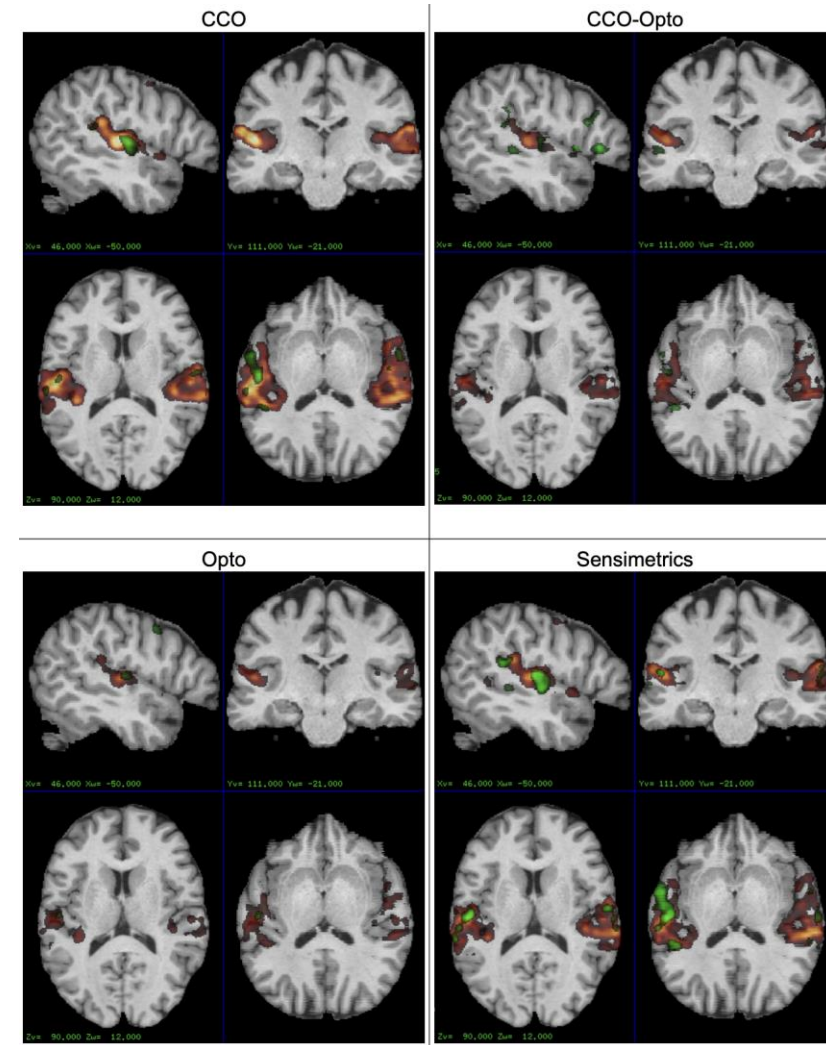

5 sound vs. silence 30

5 human vs. non vocal 10

FMRI pilot – Voice Localizer

Subject 1

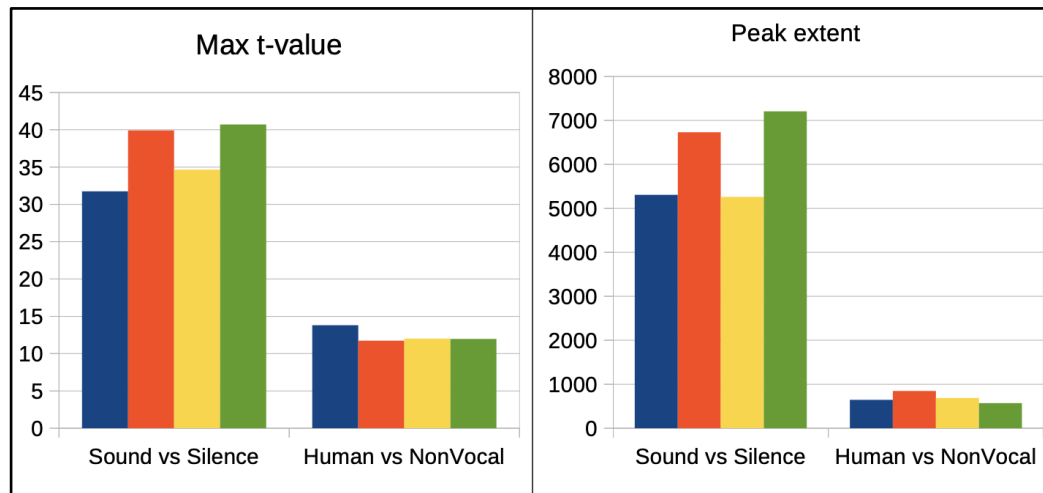

Subject 2

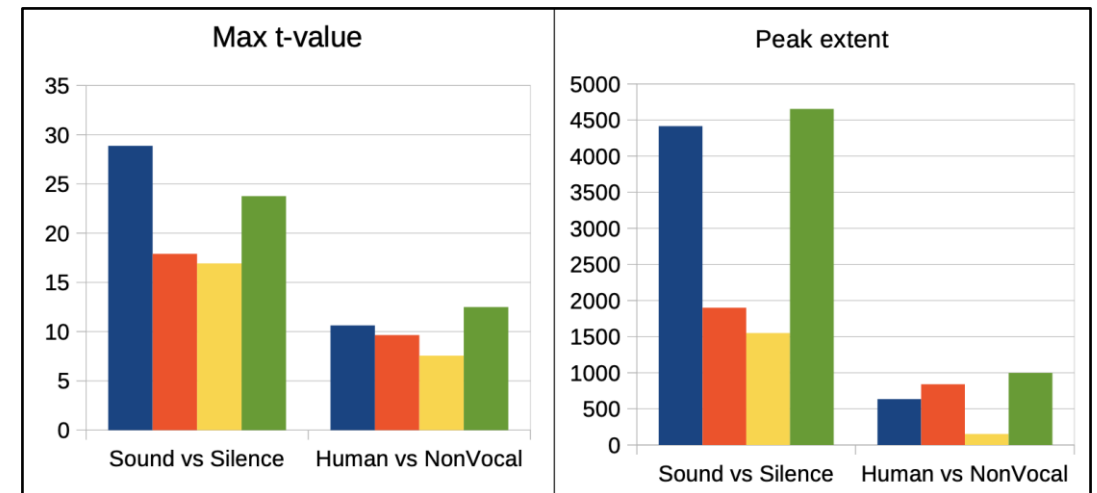

■ CCO ■ CCO-Opto ■ Opto ■ Sensimetrics

Buzzer piezo position - Session 2 (with earplugs)
No activation

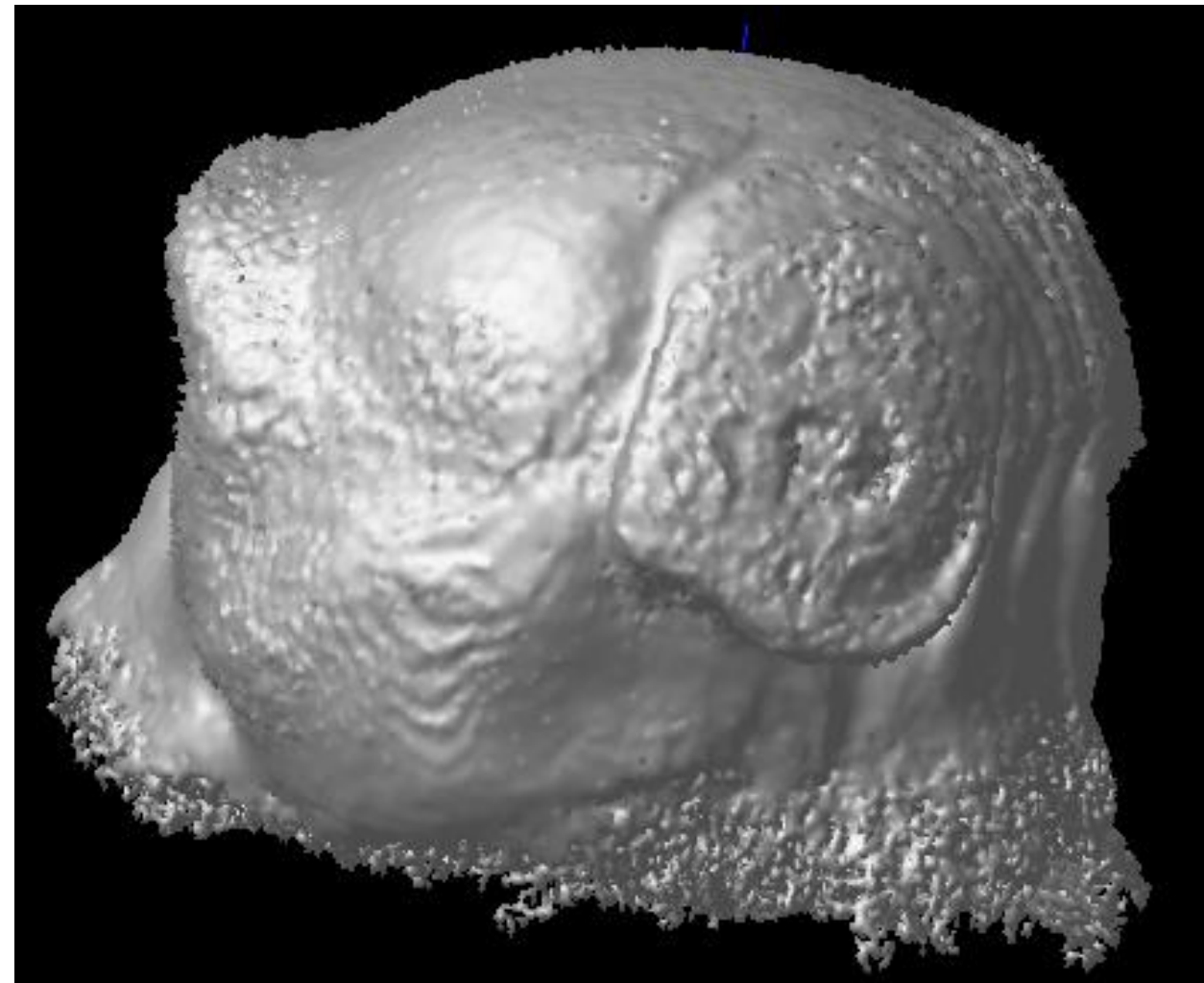
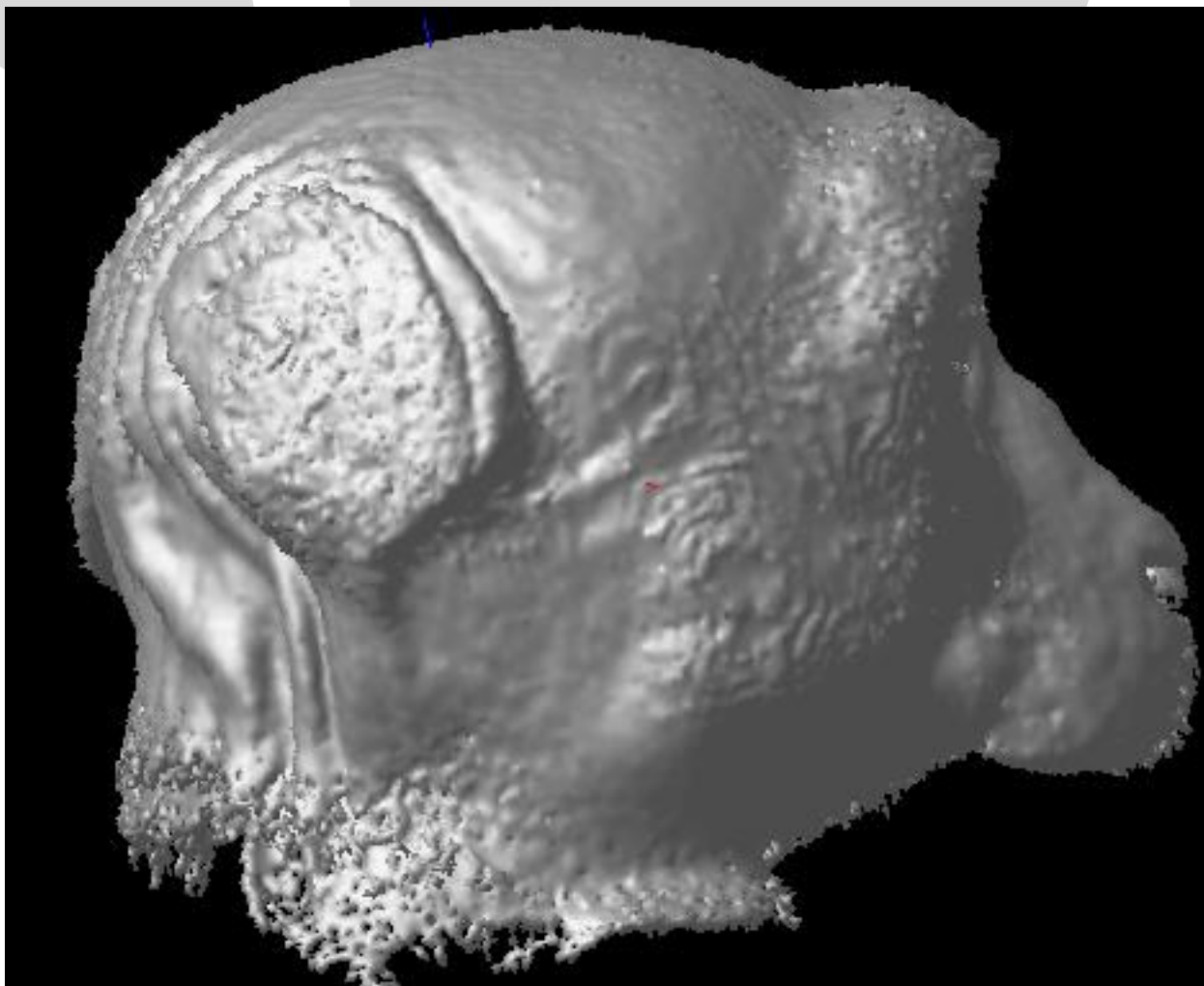

Buzzer piezo position - Session 3 (no earplugs)

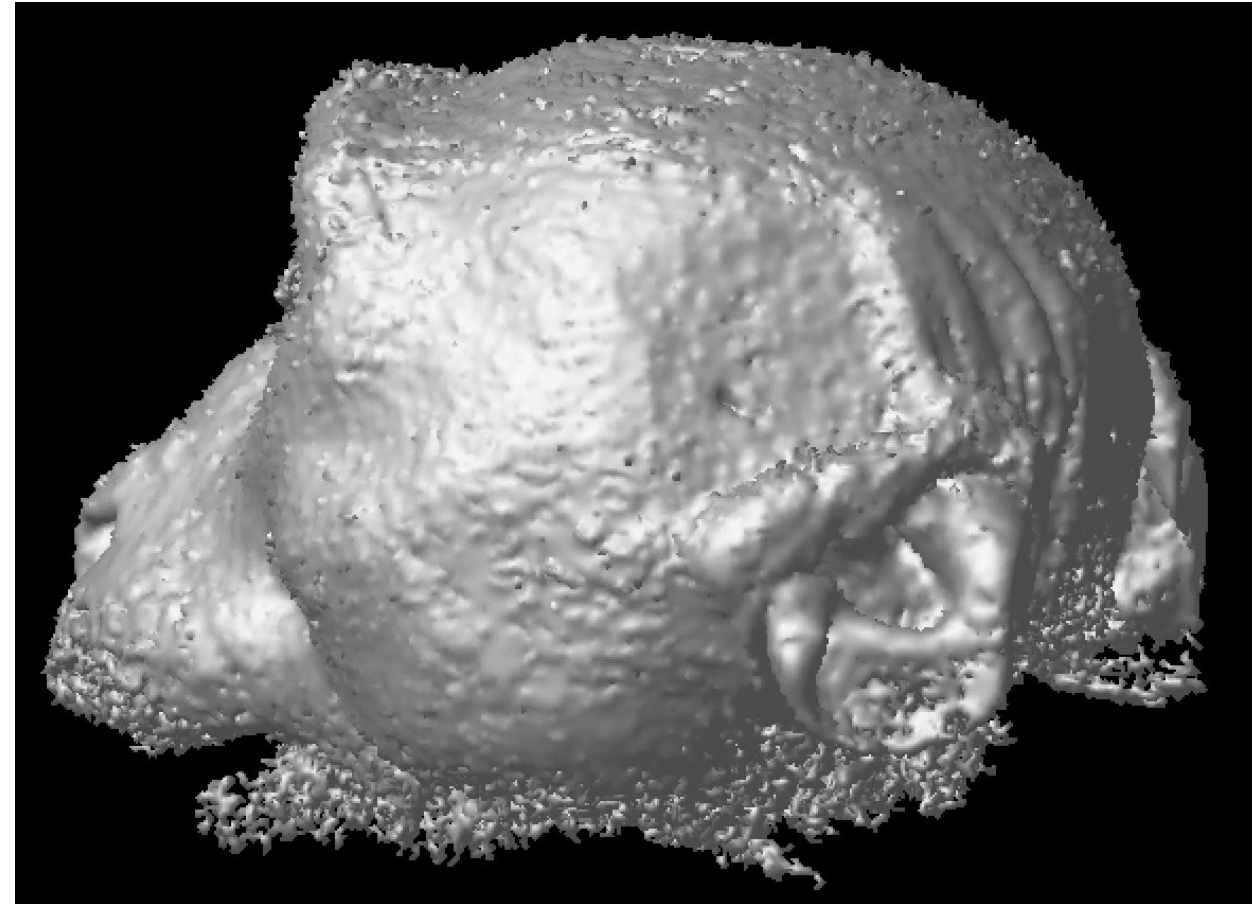
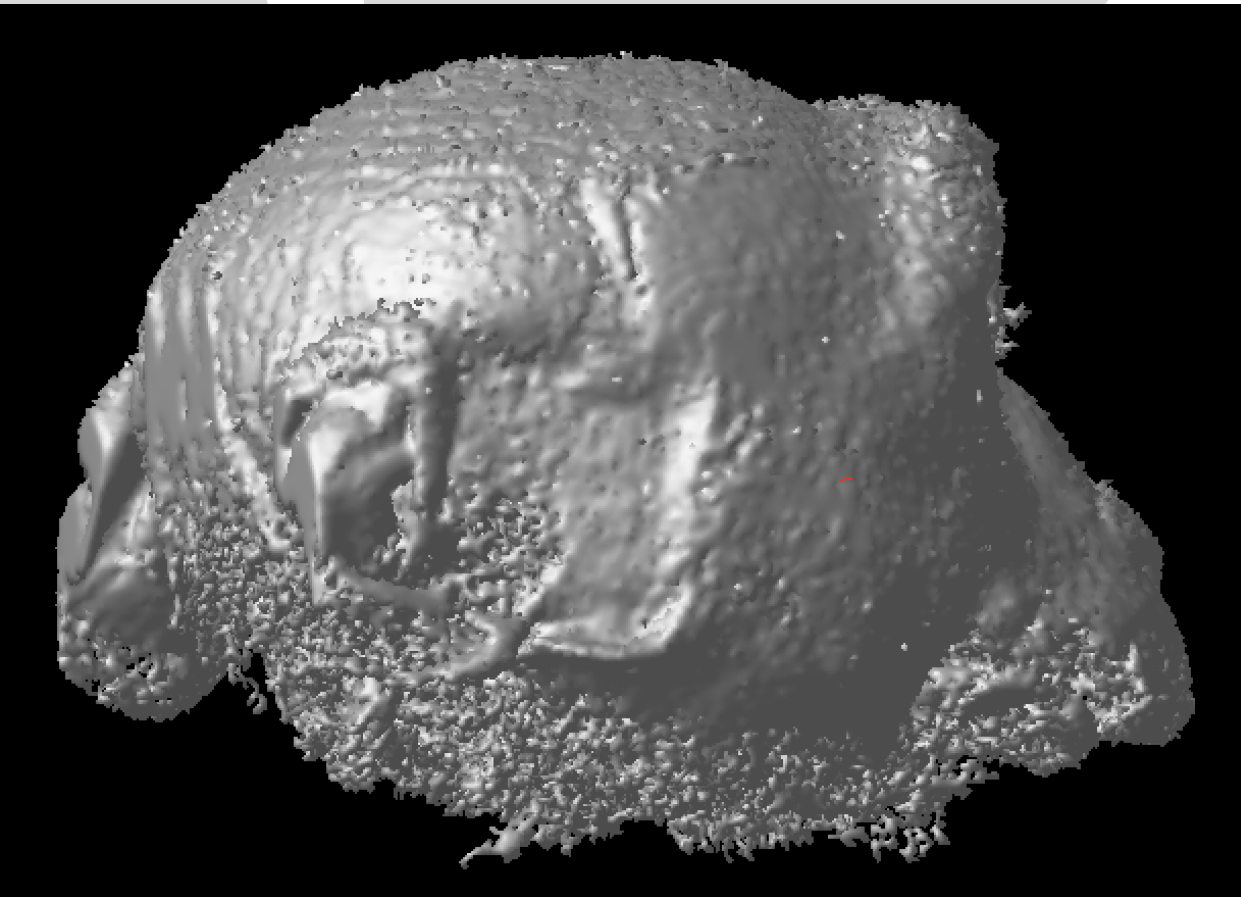

Buzzer piezo position - Session 3 (no earplugs)

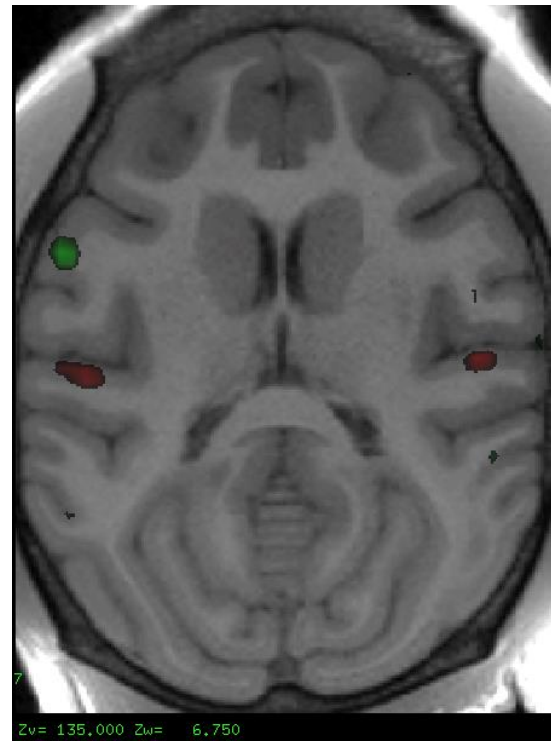
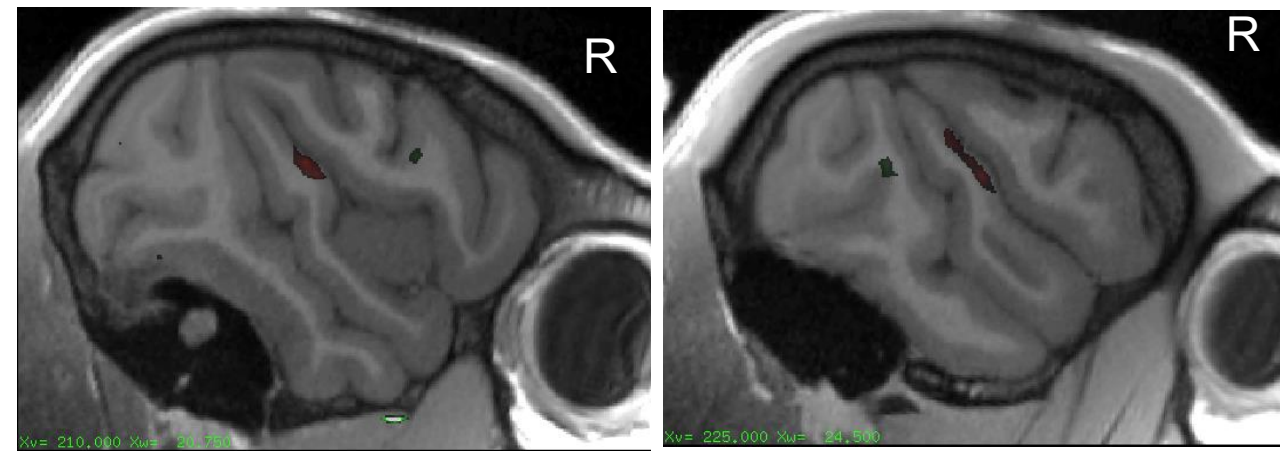
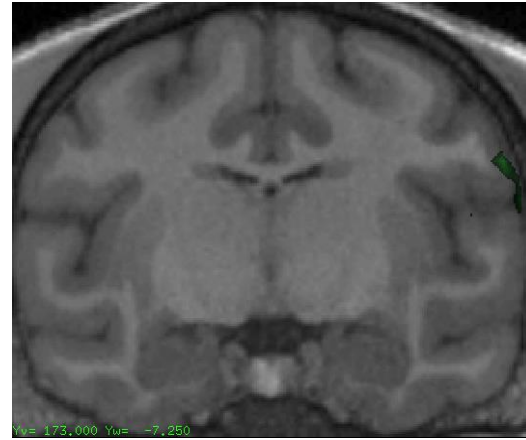
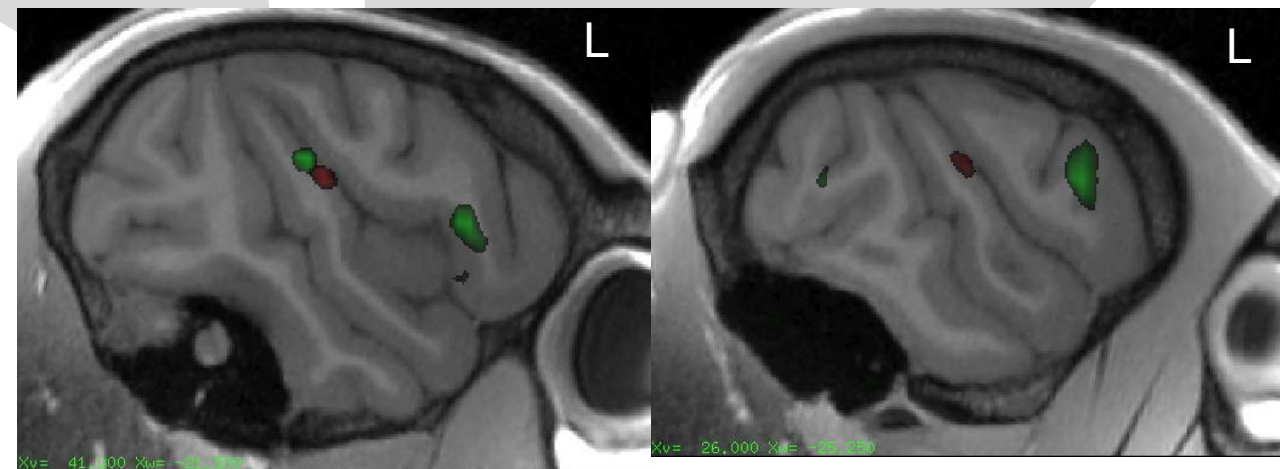

all 16 runs - session 3

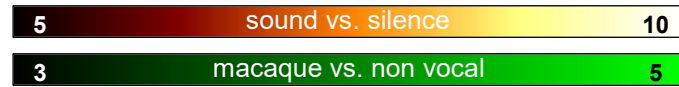

PI Piezo position - Session 4 (with earplugs)

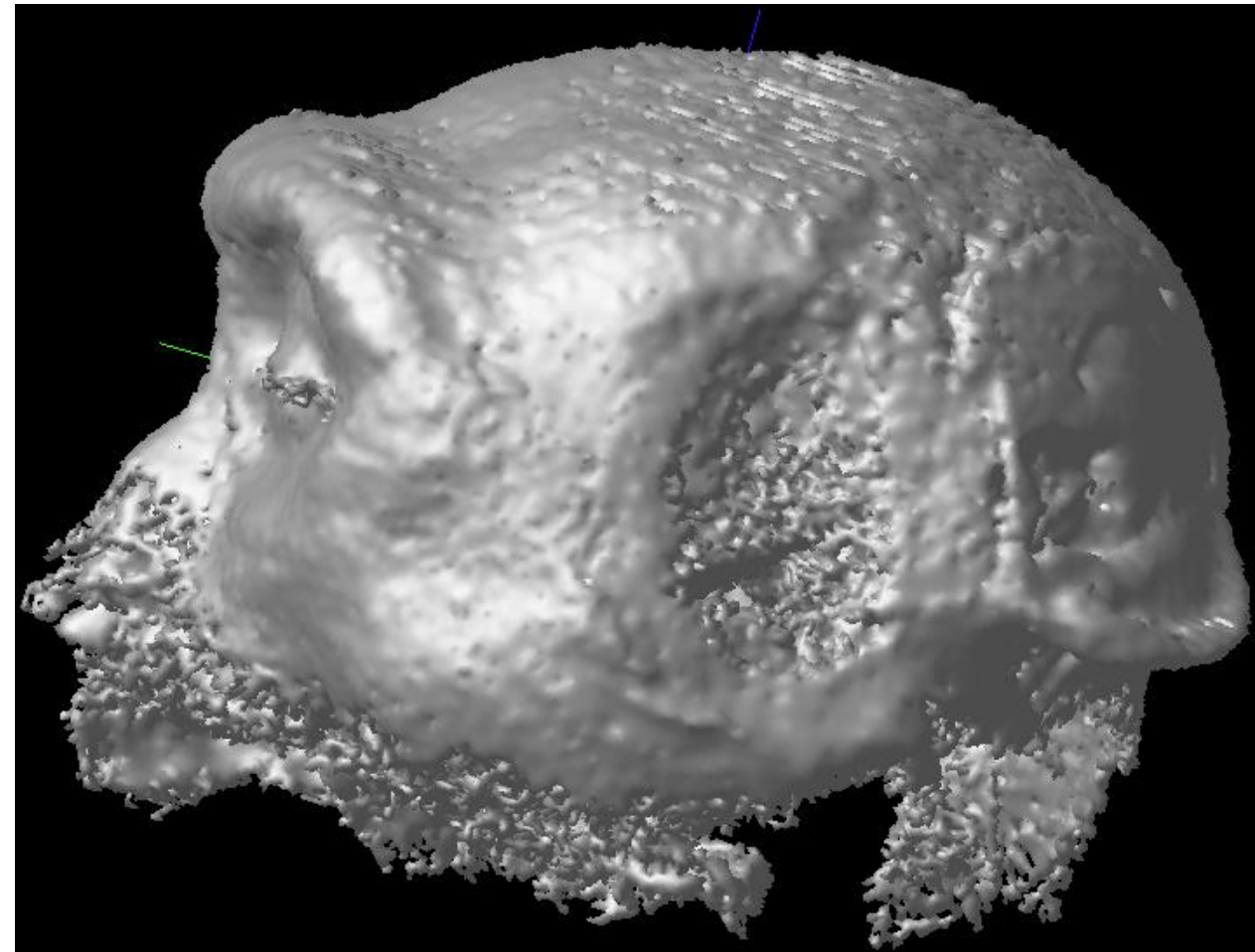
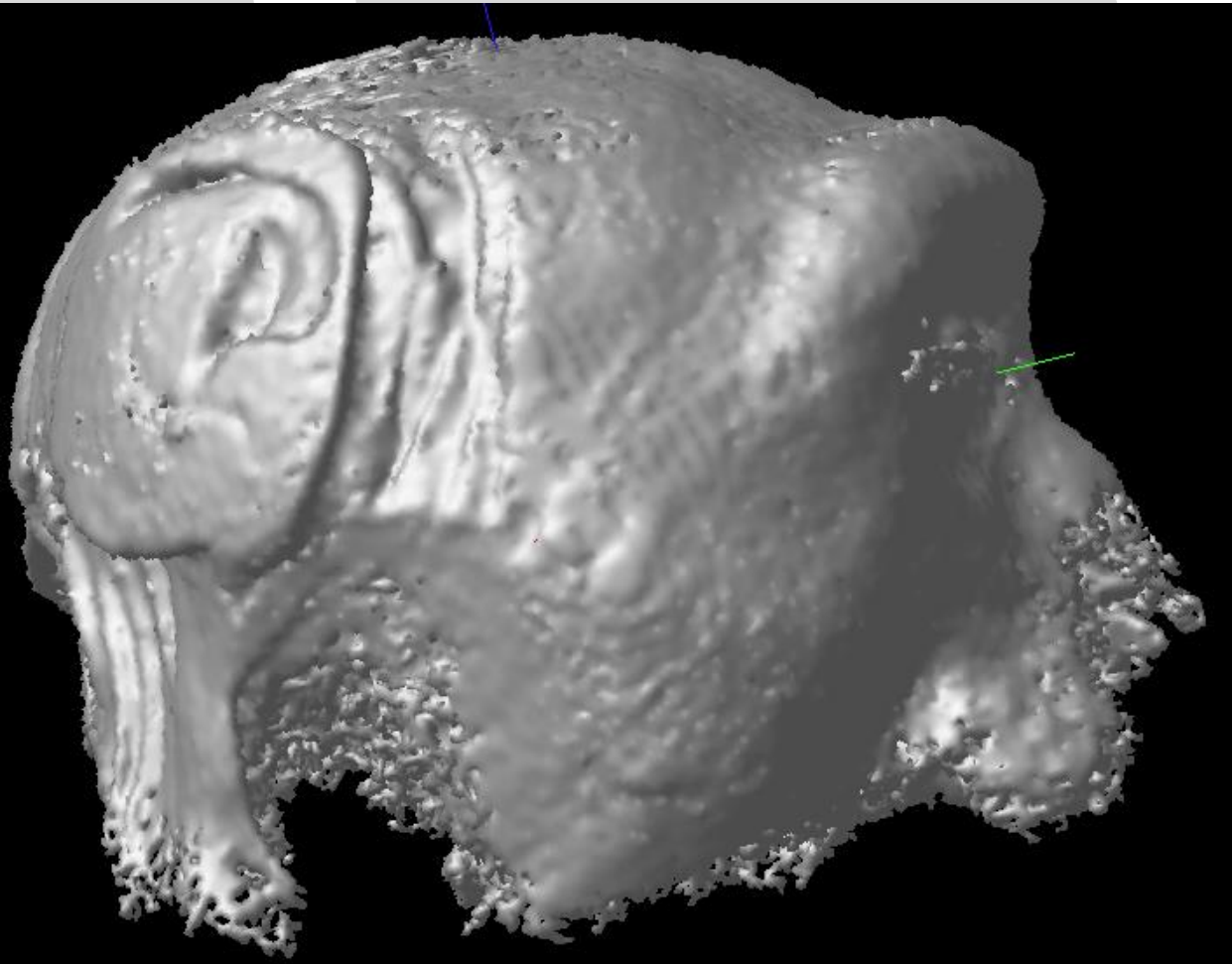

PI Piezo position - Session 4 (with earplugs)

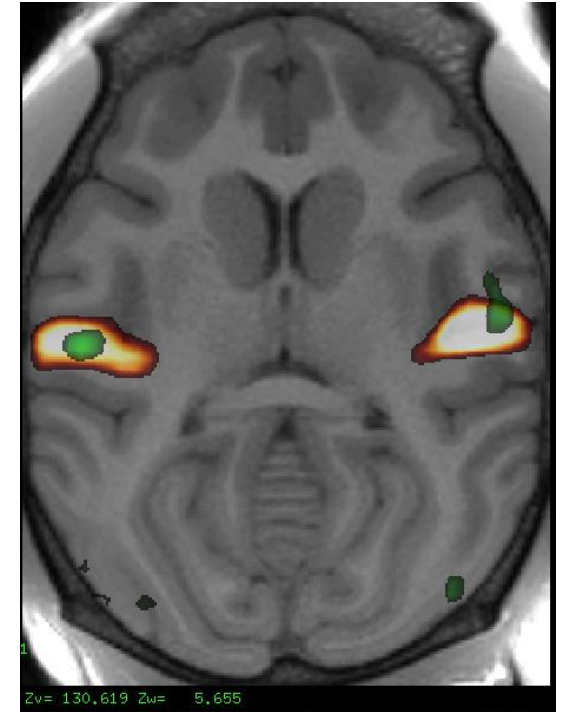
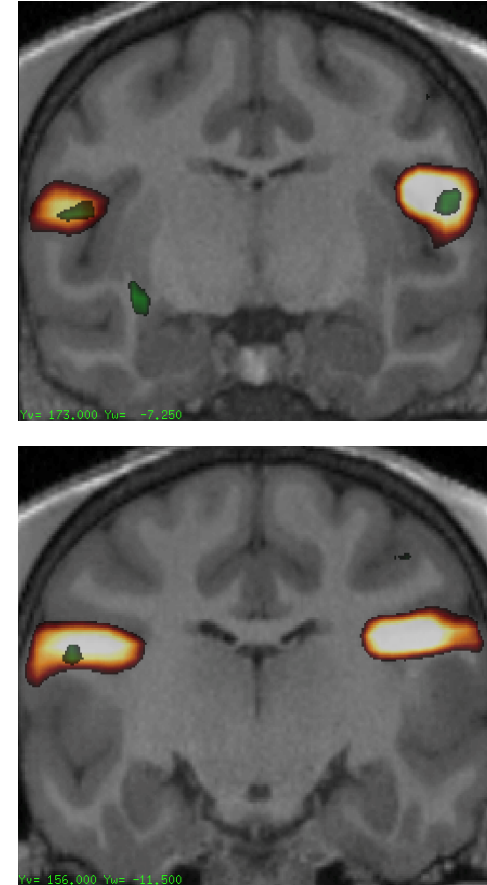
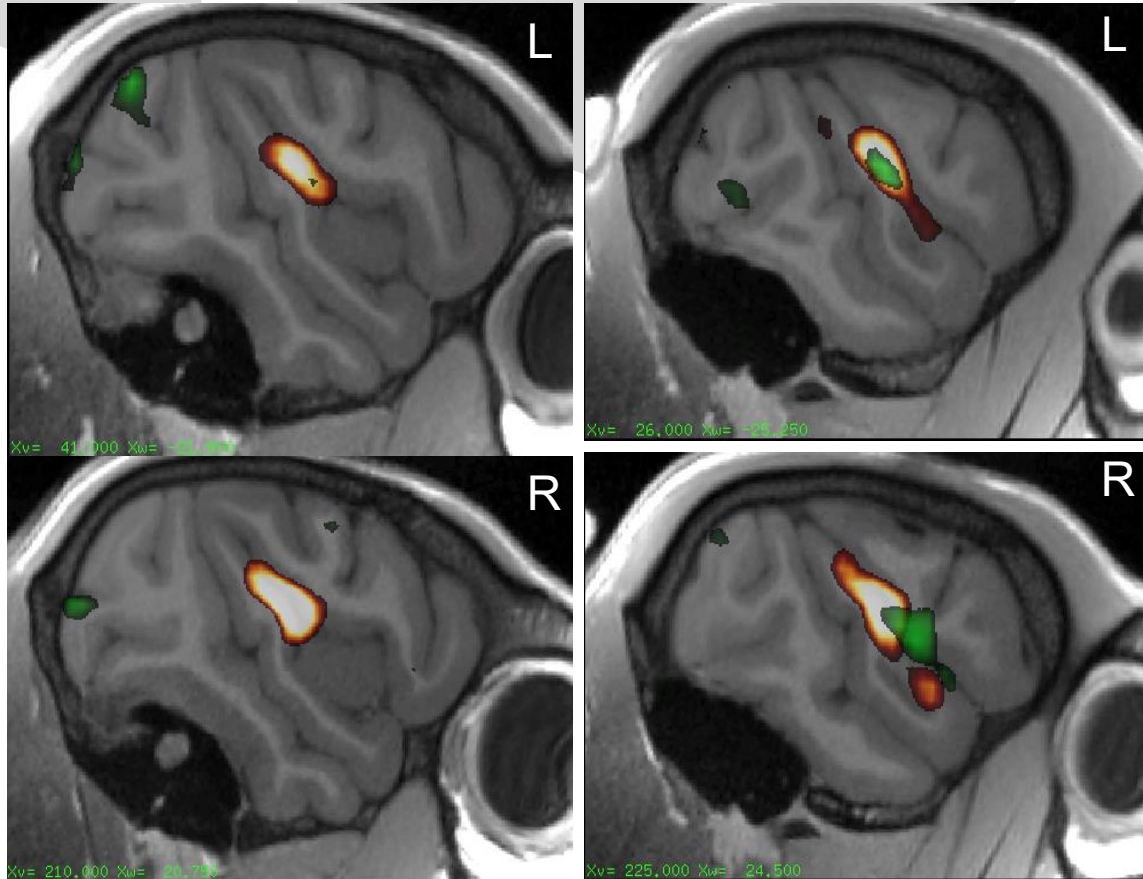

all 27 runs - session 4

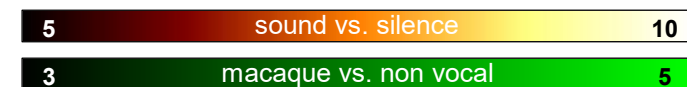

Conclusion

Psychophysical validation

- Audiogram task (frequencies detection / recognition)
- Minimal pairs task (phonetic perception)
- Test influence of position on skull
- Spectral normalization
- Link to ear protection plugs



Perspectives

- Audio
 - Stereo (& more ?) system (to be tested)
 - Head free system (coil mechanical vibration)
- Other applications
 - Tactile stimulations
 - Vestibular stimulation
 - ...



Special thanks

- Romain Poos
 - MRI Team : Jean-Luc Anton & Julien Sein
 - BANCO : Régis Trapeau, Etienne Thoret & Pascal Belin
 - PRISM new friends : Richard Kronland-Martinet, Adrien Vidal

 - Old Friends : Alain Ghio, Daniele Schön
- And Bernard Teston